

Safety Valves

Type 06216, Type 06217



Safety Valves, brass,
type tested TÜV-SV.1090 D/G

Standard safety valve
with FPM valve seal, open bonnet, with discharge holes
Inlet: male thread type G (BSPP) acc. to ISO 228/1

Part No. 06216.X.0000

Part No. 06217.X.0000

with lifting device

Available options - on request only:

- discharge holes with protection cap
- stainless steel spring - material 1.4571
- external parts nickel plated



Applications:

Provided as safety device for protection against excessive pressure in stationary and moveable gas cylinders and pressure vessels. Approved for air and similar gases.

Working temperature: -40°C / -40°F (233K) up to +200°C / +392°F (473K), suitable for horizontal installation

Materials	DIN EN	ASTM
1 Body	CW617N	B 283 UNS C37700
2 Valve seal	FPM (Viton-GLT)	
3 Disc	CW614N	B 455 UNS C38500
4 Stem	CW614N	B 455 UNS C38500
5 Bonnet	CW614N	B 455 UNS C38500
6 Spring	1.1200	A 227
7 Stem guide	PTFE	
8 Cap	CW614N	B 455 UNS C38500
9 Lifting device	CW614N	B 455 UNS C38500
10 Closing cap	CW507L	B 36 UNS C26800

Essential: Valves are delivered at a set pressure, therefore when ordering please confirm set pressure, medium and temperature.

Standard marking acc. to Pressure Equipment Directive 97/23/EC (PED).



Marking acc. to ASME Code Section VIII.

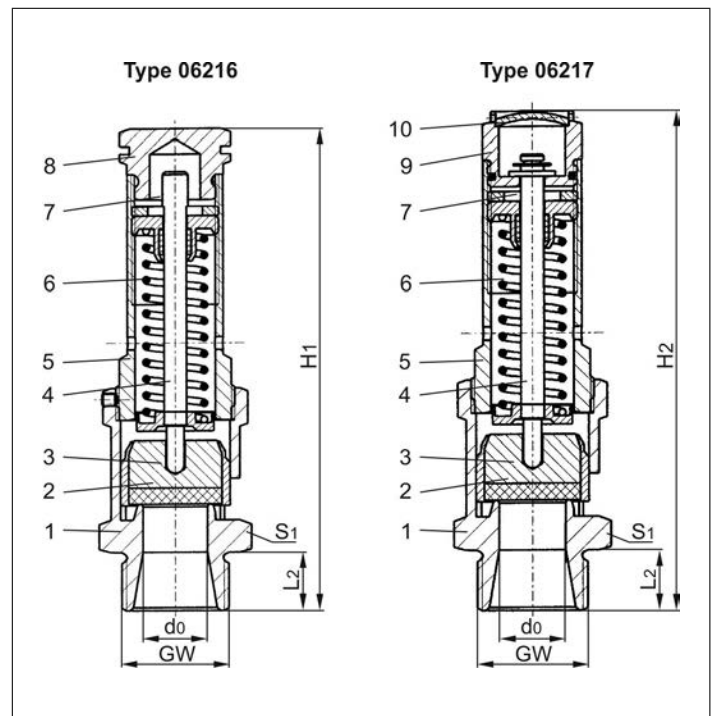

Type 06216, Type 06217	Technical data						
	GW	1/2	3/4	1	1-1/4	1-1/2	2
Nominal size	d ₀	12	15	20	25	32	40
Dimension code	.X.	0400	0600	1000	1200	1400	2000
Set pressure range	bar	0.2-25	0.2-30	0.2-30	0.2-22	0.2-16	0.2-12
Height	H ₁	103	122	149	169	198	224
Height	H ₂	107	126	150	172	200	228
Length	L ₂	14	16	18	20	22	25
Wrench size across flats	S ₁	27	32	41	50	55	70
Weight	ca. kg	0.25	0.41	0.72	1.23	1.73	3.09
Coeff. of discharge from 3.0 bar	α _w	0.83	0.83	0.73	0.71	0.69	0.66

Dimensions in mm.

Safety Valves

Type 06216, Type 06217



Discharge capacities

Medium:

Air in m³/h at 0°C and 1013.25 mbar

Air in SCFM at 60°F (15.6°C) and 14.7 psia (1013.25 mbar)

The capacity indicated below is for a fully opened valve.

d₀ - orifice

A₀ - flow area

Calculation of discharge capacity acc. to AD2000-Merkblatt A2 / DIN EN ISO 4126-1 resp. ASME Code Sec. VIII.

The safety valve is marked with the lower capacity of both calculations.

Set pressure in bar (g)	GW	1/2	3/4	1	1-1/4	1-1/2	2
	d ₀ (mm) A ₀ (mm ²) Medium	12.0 113.1	15.0 176.7	20.0 314.2	25.0 490.9	32.0 804.2	40.0 1256.6
Air in m ³ /h							
0.2		46	74	121	183	299	411
0.5		81	130	205	300	503	691
1.0		124	196	307	459	775	1085
2.0		195	307	495	752	1214	1760
3.0		260	412	674	1021	1630	2436
4.0		326	518	845	1282	2046	3057
5.0		394	622	1017	1542	2461	3679
6.0		460	728	1189	1803	2877	4300
7.0		526	833	1361	2063	3293	4921
8.0		593	939	1533	2324	3709	5543
9.0		659	1044	1704	2584	4124	6164
10.0		725	1148	1876	2843	4540	6785
12.0		859	1359	2220	3364	5371	8028
14.0		992	1569	2563	3885	6203	-
16.0		1124	1780	2907	4406	7034	-
18.0		1257	1991	3251	4927	-	-
20.0		1389	2200	3594	5448	-	-
22.0		1523	2410	3938	5969	-	-
25.0		1722	2726	4453	-	-	-
26.0		-	2832	4625	-	-	-
28.0		-	3042	4969	-	-	-
30.0		-	3253	5312	-	-	-

Set pressure in psig	GW	1/2	3/4	1	1-1/4	1-1/2	2
	d ₀ (inch) rated slope Medium	0.472 2.59	0.591 4.10	0.787 6.79	0.984 10.15	1.260 16.50	1.575 24.80
Air in SCFM							
15		78	124	194	290	490	687
30		127	195	315	479	773	1123
50		191	285	466	710	1130	1688
60		221	330	540	822	1308	1955
70		251	375	614	933	1486	2222
80		281	421	688	1045	1665	2488
90		312	466	762	1157	1843	2755
100		341	511	835	1269	2022	3022
120		402	601	981	1492	2376	3551
130		432	646	1055	1604	2554	3818
140		462	691	1129	1716	2733	4084
150		492	736	1203	1828	2911	4351
160		522	781	1277	1940	3090	4618
174		565	845	1380	2098	3340	4992
180		583	872	1424	2164	3446	-
190		613	917	1498	2276	3624	-
200		643	962	1572	2388	3803	-
220		703	1052	1719	2613	4160	-
232		739	1106	1807	2747	4374	-
240		764	1142	1866	2836	-	-
260		824	1232	2014	3060	-	-
280		884	1323	2161	3284	-	-
300		945	1413	2308	3509	-	-
319		1002	1498	2448	3721	-	-
340		1065	1593	2603	-	-	-
363		1134	1697	2772	-	-	-
380		-	1774	2897	-	-	-
400		-	1864	3045	-	-	-
420		-	1954	3192	-	-	-
435		-	2022	3302	-	-	-