

Safety Valves

Type 06472



Cryogenic Safety Valves, angle type, bronze, PN40, type tested TÜV-SV.836. S/G

Standard safety valve,
metal to metal seated, closed bonnet
Outlet: female thread type G 1/2 acc. to ISO 228/1
"cleaned and degreased for oxygen service"

Part No. 06472.X.0000

Inlet: male thread type G (BSPP) acc. to ISO 228/1

Part No. 06472.X.5000

Inlet: male thread NPT acc. to ANSI B 1.20.1

Part No. 06472.0600.0000

Inlet: union type braze fitting for pipe outside diameter 12 mm

Available options - on request only:

- external parts nickel plated
- with installed elbow at the outlet



Applications:

Provided as safety device for protection against excessive pressure in stationary and moveable gas cylinders and pressure vessels. Approved for air gases, vapours and cryogenic liquefied gases incl. LNG.
Working temperature: -196°C / -321°F (77K) up to +150°C / +302°F (423K), suitable for horizontal installation

Materials	DIN EN	ASTM
1 Outlet body	CC491K	B 62 UNS C83600
2 Inlet body	1.4301	A 276 Grade 304
4 Disc	1.4541	A 276 Grade 321
5 Guide plate	CW453K	B 103 UNS C52100
6 Stem	CW614N	B 283 UNS C38500
7 Spring	1.4571	A 313 Grade 316Ti
8 Bonnet	1.4301	A 276 Grade 304
9 Spring clamp	CW614N	B 283 UNS C38500
10 Thread ring	CW614N	B 283 UNS C38500
11 Cap	CW614N	B 283 UNS C38500
15 Braze fitting	1.4301	A 276 Grade 304
16 Union nut	CW614N	B 283 UNS C38500

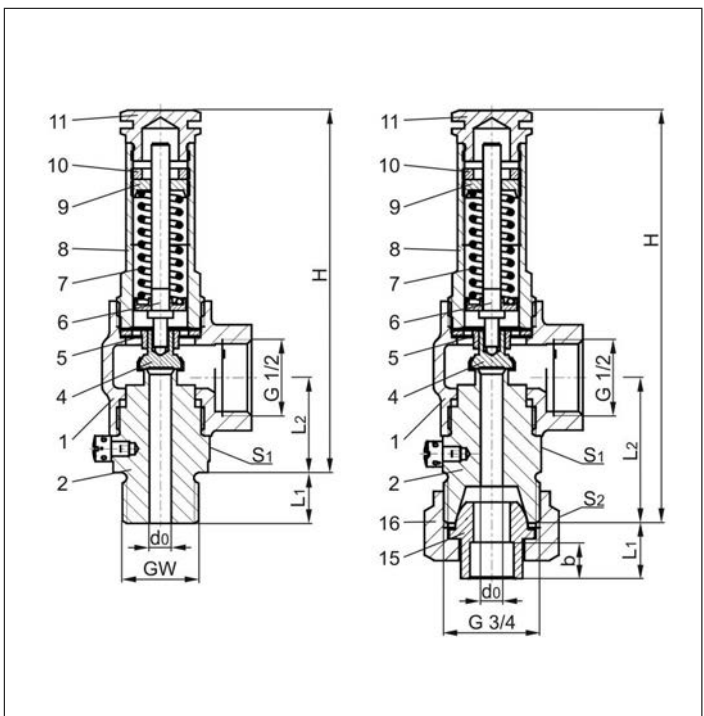

Essential: Valves are delivered at a set pressure, therefore when ordering please confirm set pressure, medium and temperature.

Standard marking acc. to Pressure Equipment Directive 97/23/EC (PED).



Type 06472	Technical data				
Nominal size	GW	1/4	3/8	1/2	3/4
Orifice	d ₀	6.0	6.0	6.0	6.0
Dimension code	.X.	0200	0300	0400	0600
Set pressure range	bar	0.5-6.0	0.5-6.0	0.5-6.0	0.5-6.0
Height	H	100	100	100	114
Length	L ₁	12	13	14	15.5
Length	L ₂	26	26	26	40
Socket depth	b	-	-	-	10
Wrench size across flats	S ₁	27	27	27	27
Wrench size across flats	S ₂	-	-	-	32
Weight	ca. kg	0.34	0.36	0.38	0.47
Coeff. of discharge from 3.0 bar	α _w	0.55	0.55	0.55	0.55

Dimensions in mm.

Safety Valves

Type 06472



Discharge capacities

Calculation of mass flow acc. to AD2000-Merkblatt A2 / DIN EN ISO 4126-1

Medium:

Air in m³/h at 0°C and 1013.25 mbar

The capacity indicated below is for a fully opened valve.

d₀ - orifice

A₀ - flow area

Set pressure in bar (g)	GW	1/4	3/8	1/2	3/4
	d ₀ (mm) A ₀ (mm ²) Medium	6.0 28.3	6.0 28.3	6.0 28.3	6.0 28.3
Air					
0.5		13	13	13	13
0.6		15	15	15	15
0.7		17	17	17	17
0.8		18	18	18	18
0.9		19	19	19	19
1.0		21	21	21	21
1.2		23	23	23	23
1.4		26	26	26	26
1.6		28	28	28	28
1.8		31	31	31	31
2.0		33	33	33	33
2.2		36	36	36	36
2.4		38	38	38	38
2.6		40	40	40	40
2.8		43	43	43	43
3.0		45	45	45	45
3.2		48	48	48	48
3.4		50	50	50	50
3.6		52	52	52	52
3.8		55	55	55	55
4.0		57	57	57	57
4.2		59	59	59	59
4.4		62	62	62	62
4.6		64	64	64	64
4.8		66	66	66	66
5.0		69	69	69	69
5.2		71	71	71	71
5.4		73	73	73	73
5.6		76	76	76	76
5.8		78	78	78	78
6.0		80	80	80	80