

Safety Valves

Type 06441



Cryogenic Safety Valves, angle type, stainless steel, PN40
 $d_0=7,0$ & $10,5$ mm up to PN50,
 type tested TÜV-SV.1111. S/G

Standard safety valve,
 with PCTFE valve seal (D_07 = Metal to metal seated), closed bonnet
 "cleaned and degreased for oxygen service"

Part No. 06441.X.0000

Inlet: female thread type G (BSPP) acc. to ISO 228/1
 Outlet: female thread type G (BSPP) acc. to ISO 228/1



Applications:

Provided as safety device for protection against excessive pressure in stationary and moveable gas cylinders and pressure vessels. Approved for air gases, vapours and cryogenic liquefied gases incl. LNG.
 Working temperature: -196°C / -321°F (77K) up to $+185^{\circ}\text{C}$ / $+365^{\circ}\text{F}$ (458K), with PCTFE-seal up to $+150^{\circ}\text{C}$ / 302°F (423K), suitable for horizontal installation

Materials	DIN EN	ASTM
1 Outlet body	1.4308	SA351 CF8
2 Inlet body	1.4301	A 479 Grade 304
3 Vasal seal	PCTFE	
4 Disc (D_07 only)	1.4571	A 479 Grade 316Ti
4 Disc	1.4541	A 276 Grade 321
5 Guide plate	1.4301	A 479 Grade 304
6 Stem	1.4301	A 479 Grade 304
7 Spring	1.4571	A 313 Grade 316Ti
8 Bonnet	1.4308	SA351 CF8
8a Bonnet from GW 1-1/4	1.4301	A 276 Grade 304
9 Spring clamp	1.4301	A 479 Grade 304
10 Thread ring	1.4301	A 479 Grade 304
11 Cap	1.4301	A 479 Grade 304

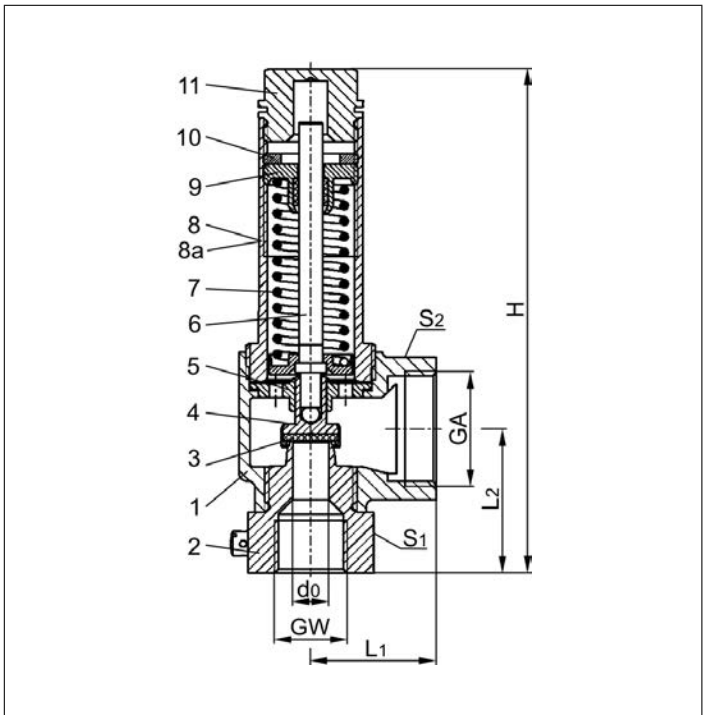

Essential: Valves are delivered at a set pressure, therefore when ordering please confirm set pressure, medium and temperature.

Standard marking acc. to Pressure Equipment Directive 97/23/EC (PED).



Type 06421	Technical data					
Nominal size	GW	1/2	1/2	3/4	1	1-1/4
Orifice	d_0	7.0	10.5	14.0	18.0	23.0
Dimension Code	.X.	0704	1004	1406	1810	2312
Set pressure range	bar	0.4-50.0	0.4-50.0	0.4-40.0	0.4-40.0	0.4-10.0
Outlet	GA	1	1	1-1/4	1-1/2	1-1/2
Height	H	145	145	164	195	200
Length	L_1	36	36	50	48	48
Length	L_2	41.5	41.5	49	59.5	65
Wrench size across flats	S_1	36	36	41	50	50
Wrench size across flats	S_2	41	41	50	58	58
Weight	ca. kg	0.80	0.795	1.25	1.87	1.79
Coeff. of discharge from 3.0 bar	α_w	0.78	0.69	0.66	0.66	0.54

Dimensions in mm.

Safety Valves

Type 06441



Discharge capacities

Calculation of mass flow acc. to AD2000-Merkblatt A2 / DIN EN ISO 4126-1

Medium:

Air in m³/h at 0°C and 1013.25 mbar

The capacity indicated below is for fully opened valve.

d₀ - orifice

A₀ - flow area

Set pressure in bar (g)	GW	1/2	1/2	3/4	1	1-1/4
	d ₀ (mm)	7.0	10.5	14.0	18.0	23.0
A ₀ (mm ²)	38.48	86.6	153.9	254.5	415.3	
Medium	Air					
0.4		24	43	77	122	157
0.5		27	49	87	141	178
1.0		40	77	130	216	287
1.5		54	101	178	290	375
2.0		65	126	219	362	472
3.0		88	175	299	494	660
4.0		110	220	375	620	829
5.0		133	266	452	748	999
6.0		156	311	529	874	1168
7.0		178	356	605	1001	1337
8.0		202	402	684	1130	1510
9.0		224	447	760	1257	1680
10.0		247	493	839	1387	1853
12.0		293	583	992	1641	-
14.0		338	674	1146	1895	-
16.0		384	764	1300	2149	-
18.0		429	855	1453	2403	-
20.0		479	954	1623	2682	-
22.0		525	1045	1778	2939	-
24.0		571	1136	1933	3195	-
25.0		594	1182	2010	3324	-
26.0		617	1228	2088	3452	-
28.0		662	1319	2243	3708	-
30.0		715	1423	2421	4002	-
32.0		761	1516	2577	4261	-
34.0		807	1608	2734	4520	-
36.0		854	1700	2891	4779	-
38.0		900	1792	3047	5038	-
40.0		954	1900	3231	5342	-
42.0		1001	1993	-	-	-
44.0		1048	2086	-	-	-
46.0		1094	2179	-	-	-
48.0		1141	2272	-	-	-
50.0		1198	2385	-	-	-