

# Safety Valves

## Type 06425



**Cryogenic Safety Valves, angle type, bronze, PN40**

**d<sub>0</sub>=7.0 & 10.5mm up to PN50**

**type tested TÜV-SV.1111. S/G**

Standard safety valve,

with PCTFE valve seal (D<sub>0</sub>7 = Metal to metal seated), closed bonnet, with lifting device

"cleaned and degreased for oxygen service"

**Part No. 06425.X.0000**

Inlet: male thread type G (BSPP) acc. to ISO 228/1, Outlet: female thread type G (BSPP) acc. to ISO 228/1

**Part No. 06425.X.2000**

Inlet: male thread type R (BSPT) acc. to 7/1, Outlet: female thread type G (BSPP) acc. to ISO 228/1

**Part No. 06425.X.5000**

Inlet: male thread NPT acc. to ANSI B 1.20.1, Outlet: female thread type G (BSPP) acc. to ISO 228/1

**Part No. 06425.X.6000**

Inlet: male thread NPT acc. to ANSI B 1.20.1, Outlet: female thread NPT acc. to ANSI B 1.20.1



**Applications:**

Provided as safety device for protection against excessive pressure in stationary and moveable gas cylinders and pressure vessels. Approved for air gases, vapours and cryogenic liquefied gases incl. LNG.

Working temperature: -196°C / -321°F (77K) up to +185°C / +365°F (458K), with PCTFE-seal up to +150°C / 302°F (423K), suitable for horizontal installation

Materials	DIN EN	ASTM
1 Outlet body	CC491K	SB 62 UNS C83600
2 Inlet body	1.4301	SA 479 Grade 304
3 Valve seal	PCTFE	
4 Disc	CC493K	B 505 UNS C93200
5 Guide plate	CC493K	B 505 UNS C93200
6 Stem	CW453K	B 103 UNS C52100
7 Spring	1.4571	A 313 Grade 316Ti
8 Bonnet	1.4308	SA351 CF8
8a Bonnet from GW 1-1/4	1.4301	A 276 Grade 304
9 Spring clamp	CW614N	B 455 UNS C38500
10 Thread ring	CW614N	B 455 UNS C38500
11 Lifting cap	CW614N	B 455 UNS C38500
12 Lifting spring	1.4571	A 313 Grade 316Ti
13 Lifting stem	CW614N	B 455 UNS C38500
14 Lever	1.4408	SA351 CF8M

**Essential:** Valves are delivered at a set pressure, therefore when ordering please confirm set pressure, medium and temperature.

Standard marking acc. to Pressure Equipment Directive 97/23/EC (PED).

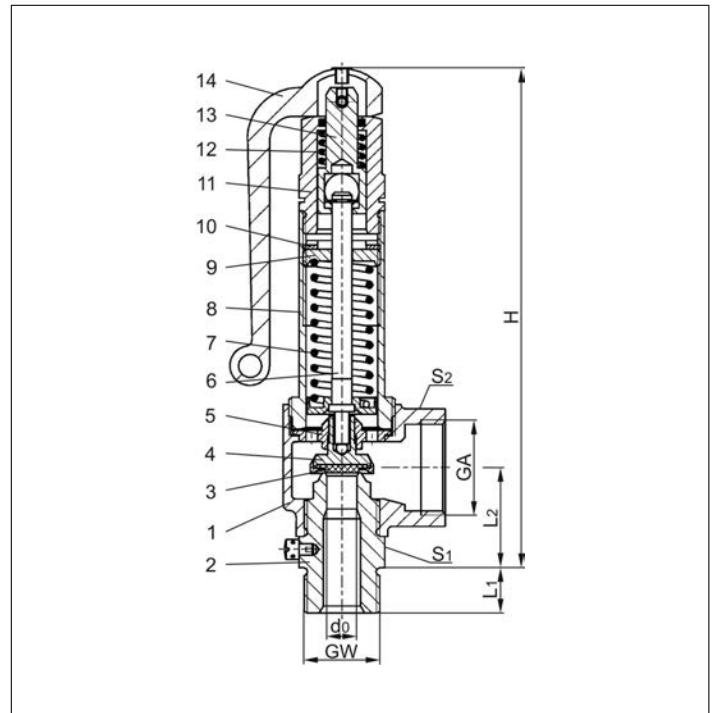

Type 06425	Technical data									
	GW	1/2	3/4	1/2	3/4	3/4	1	1	1-1/4	1-1/4
Nominal size	d <sub>0</sub>	7.0	7.0	10.5	10.5	14.0	14.0	18.0	18.0	23.0
Dimension code	.X.	0704	0706	1004	1006	1406	1410	1810	1812	2312
Set pressure range	bar	0.4-50.0	0.4-50.0	0.4-50.0	0.4-50.0	0.4-40.0	0.4-40.0	0.4-40.0	0.4-40.0	0.4-10.0
Outlet	GA	1	1	1	1	1-1/4	1-1/4	1-1/2	1-1/2	1-1/2
Height	H	176	176	176	176	196	196	239	240	239
Length	A <sub>1</sub>	14	16	14	16	16	18	18	20	20
Length	L <sub>1</sub>	36	36	36	36	50	50	48	48	48
Length	L <sub>2</sub>	36.5	36.5	36.5	34.5	44	44	50.5	51.5	52
Wrench size across flats	S <sub>1</sub>	30	30	30	30	41	41	50	50	50
Wrench size across flats	S <sub>2</sub>	41	41	41	41	50	50	58	58	58
Weight	ca. kg	1.00	1.02	0.98	1.01	1.50	1.56	2.51	2.63	2.52
Coeff. of disch. from 3.0 bar	α <sub>w</sub>	0.78	0.78	0.69	0.69	0.66	0.66	0.66	0.66	0.54

Dimensions in mm.

# Safety Valves

## Type 06425



### Discharge capacities

Calculation of mass flow acc. to AD2000-Merkblatt A2 / DIN EN ISO 4126-1

Medium:

Air in m<sup>3</sup>/h at 0°C and 1013.25 mbar

**The capacity indicated below is for a fully opened valve.**

d<sub>0</sub> - orifice

A<sub>0</sub> - flow area

Set pressure in bar (g)	GW	1/2 & 3/4	1/2 & 3/4	3/4 & 1	1 & 1-1/4	1-1/4
	d <sub>0</sub> (mm)	7.0	10.5	14.0	18.0	23.0
	A <sub>0</sub> (mm <sup>2</sup> )	38.48	86.6	153.9	254.5	415.3
	Medium	Air				
0.4		24	43	77	122	157
0.5		27	49	87	141	178
1.0		40	77	130	216	287
1.5		54	101	178	290	375
2.0		65	126	219	362	472
3.0		88	175	299	494	660
4.0		110	220	375	620	829
5.0		133	266	452	748	999
6.0		156	311	529	874	1168
7.0		178	356	605	1001	1337
8.0		202	402	684	1130	1510
9.0		224	447	760	1257	1680
10.0		247	493	839	1387	1853
12.0		293	583	992	1641	-
14.0		338	674	1146	1895	-
16.0		384	764	1300	2149	-
18.0		429	855	1453	2403	-
20.0		479	954	1623	2682	-
22.0		525	1045	1778	2939	-
24.0		571	1136	1933	3195	-
25.0		594	1182	2010	3324	-
26.0		617	1228	2088	3452	-
28.0		662	1319	2243	3708	-
30.0		715	1423	2421	4002	-
32.0		761	1516	2577	4261	-
34.0		807	1608	2734	4520	-
36.0		854	1700	2891	4779	-
38.0		900	1792	3047	5038	-
40.0		954	1900	3231	5342	-
42.0		1001	1993	-	-	-
44.0		1048	2086	-	-	-
46.0		1094	2179	-	-	-
48.0		1141	2272	-	-	-
50.0		1198	2385	-	-	-