

Safety Valves

Type 06002 - gastight



Cryogenic Safety Valves, angle type, brass, PN63, type tested TÜV-SV.1048. S/G

Standard Safety Valve,
gastight, closed bonnet
with carbon filled PTFE valve seal

Outlet: female thread Rc 3/8 acc. to ISO 7/1
"cleaned and degreased for oxygen service"

Part No. 06002.X.0020

Inlet: male thread type R (BSPT) acc. to ISO 7/1

Part No. 06002.X.2020

Inlet: male thread type G (BSPP) acc. to ISO 228/1

Part No. 06002.X.5020

Inlet: male thread NPT acc. to ANSI B 1.20.1

Available options - on request only:

- with installed elbow at the outlet



Applications:

Provided as safety device for protection against thermal expansion in pipeworks and parts of facilities.

Approved for air gases, vapours and cryogenic liquefied gases incl. LNG.

Working temperature: -196°C / -321°F (77K) up to +150°C / +302°F (423K), suitable for horizontal installation

Materials	DIN EN	ASTM
1 Body	CW610N	B 111 UNS C36500
2 Valve seal	PTFE / Carbon filled (25%)	
3 Disc	CW452K	B 159 UNS C51900
4 Guide plate	CC493K	B 505 UNS C93200
5 Stem	CW614N	B 283 UNS C38500
6 Spring	1.4571	A 313 Grade 316Ti
7 Bonnet	CW614N	B 283 UNS C38500
8 Spring clamp	CW614N	B 283 UNS C38500
9 Thread ring	CW614N	B 283 UNS C38500
10 Cap	CW614N	B 283 UNS C38500

Essential: Valves are delivered at a set pressure, therefore when ordering please confirm set pressure, medium and temperature.

Standard marking acc. to Pressure Equipment Directive 97/23/EC (PED).

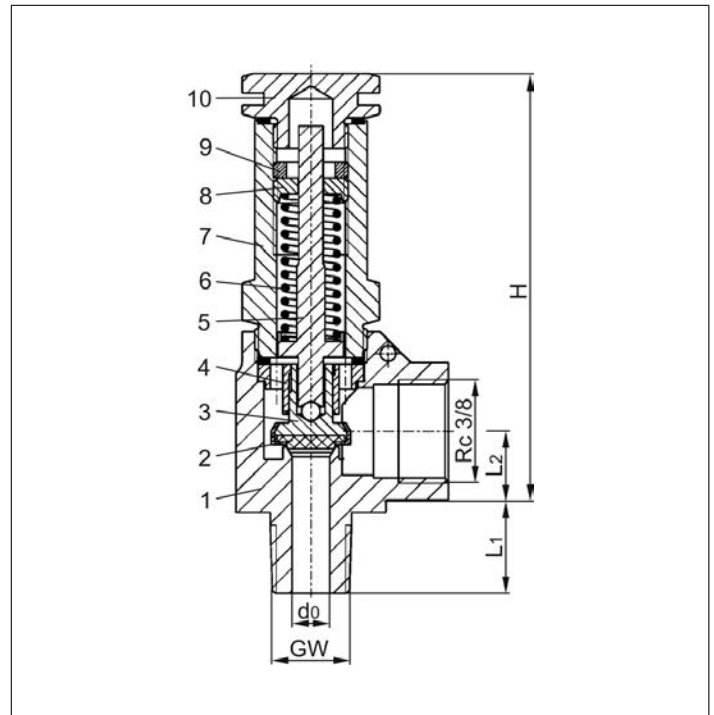

Type 06002	Technical data				
	Nominal size	GW	1/4	3/8	1/2
Orifice	d ₀	6.0	6.0	6.0	6.0
Dimension code	.X.	0200	0300	0400	
Set pressure range	bar	1.0-55.0	1.0-55.0	1.0-55.0	1.0-55.0
Height	H	70	70	70	
Length	L ₁	13	15	17	
Length	L ₂	13	13	13	
Weight	ca. kg	0.18	0.20	0.22	
Coefficient of discharge	α _w	0.34	0.34	0.34	

Dimensions in mm.

Safety Valves

Type 06002 - gastight



Discharge capacities

Calculation of mass flow acc. to AD2000-Merkblatt A2 / DIN EN ISO 4126-1

Medium:

Air in m³/h at 0°C and 1013.25 mbar

The capacity indicated below is for a fully opened valve.

d₀ - orifice

A₀ - flow area

Set pressure in bar (g)	GW	1/4, 3/8 & 1/2
	d ₀ (mm)	6.0
	A ₀ (mm ²)	28.3
	Medium	Air
1.0		12.0
2.0		20.0
3.0		28.0
4.0		35.0
5.0		42.0
6.0		50.0
7.0		57.0
8.0		64.0
9.0		71.0
10.0		79.0
12.0		93.0
14.0		108.0
16.0		123.0
18.0		137.0
20.0		153.0
22.0		168.0
24.0		182.0
26.0		197.0
28.0		212.0
30.0		229.0
32.0		243.0
34.0		258.0
36.0		273.0
38.0		288.0
40.0		305.0
42.0		320.0
44.0		335.0
46.0		350.0
48.0		365.0
50.0		383.0
52.0		398.0
54.0		413.0
55.0		421.0