

Globe Valves

Type 03321 - Globe Valve, DIN EN Flanges



Cryogenic-Globe and Globe/Check Valves, PN40

Stainless steel body and bronze topwork,
 "live loaded" gland packing
 "cleaned and degreased for oxygen service"

Part No. 03321.X.0012 (H = 270mm)

Part No. 03321.X.0022 (H = 370mm)

Part No. 03321.X.5012 (H = 270mm) Globe/Check Valve

Part No. 03321.X.5022 (H = 370mm) Globe/Check Valve

Flanged connection acc. to DIN EN 1092-1 PN40

Available options - on request only:

- Extension H up to 900mm
- Valve with control disc (tapered design)
- Nominal sizes DN15, DN20 and DN150 with welding-neck flange



Applications:

Approved for air gases, vapours and cryogenic liquefied gases incl. LNG.

Working temperature: -196°C / -321°F (77K) up to +120°C / +248°F (393K)

Materials	DIN EN	ASTM
1 Body	1.4308	A 351 CF8
2 Valve seal up to DN50	PTFE / Carbon filled (25%)	
2a Valve seal from DN65	PTFE	
3 Disc	CW614N	B 283 UNS C38500
4 Bonnet gasket	PTFE	
5 Headpiece	CC493K	B 505 UNS C93200
6 Bolts	1.4301/A2	A 194 B8
7 Elongation tube	1.4541	A 213 TP 321
8 Stem	1.4301	A 276 Grade 304
9 Gland packing	Graphite / PTFE	
10 Gland nut	CW614N	B 283 UNS C38500
11 Handwheel	Aluminium alloy	
12 Spring	CW452K	B 159 UNS C51900

Standard marking acc. to Pressure Equipment Directive 97/23/EC (PED).

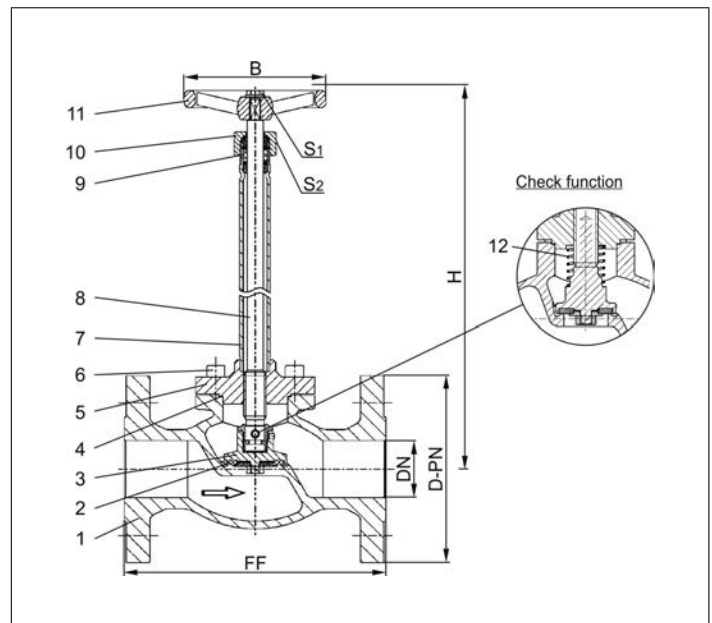

Type 03321 - Standard design	Technical data						
	DN	25	40	50	65	80	100
Nominal size	.X.	0250	0400	0500	0650	0800	1000
Dimension code - Flange EN 1092-1 PN40	D-PN	115	150	165	185	200	235
Flange-Ø	FF	160	200	230	290	310	350
Face-to-face dimension	H	270 mm or 370 mm			400	400	400
Height	B	100	125	125	200	250	315
Handwheel-Ø	S ₁	10	13	13	13	13	13
Wrench size across flats	S ₂	30	36	36	36	36	41
Wrench size across flats	ca. kg	4.9	9.7	13.3	21.1	28.0	43.2
Weight	m ³ /h	11.5	22.6	37.1	71.1	104.0	170.0
Kvs-Value	gal/min	13.4	26.3	43.2	82.7	120.9	195.2
Cv-Value							

Dimensions in mm.