

# Globe Valves

## Type 01252 - Bellow Sealed Globe Valve



### Cryogenic-Bellow Sealed Globe Valve, PN50

Stainless steel body and topwork,  
 "live loaded" gland packing  
 "cleaned and degreased for oxygen service"

#### Part No. 01252.X.002\*

\* Butt weld connection for stainless steel pipes acc. to ISO 1127 or ASTM A312

#### Part No. 01252.X.0024

Socket weld connection for stainless steel pipes acc. to ISO 1127 or ASTM A312

Available options - on request only:

- Welded stainless steel stubs acc. to ISO 1127 or ASTM A312 - length FF + 200mm
- Extension H up to 900mm
- Valve with control disc (tapered design)



### Applications:

Approved for air gases, vapours and cryogenic liquefied gases incl. LNG.  
 Working temperature: -196°C / -321°F (77K) up to +120°C / +248°F (393K)  
 Leak rate: 10<sup>-6</sup> mbar ltr / sec outside  
 10<sup>-4</sup> mbar ltr / sec seat

Materials	DIN EN	ASTM
1 Body	1.4308	A 351 CF8
2 Valve seal	PTFE / Carbon filled (25%)	
3 Disc	1.4301	A 276 Grade 304
4 Bonnet gasket	PTFE	
5 Headpiece	1.4301	A 276 Grade 304
6 Bellow stem	1.4571	A 276 Grade 316Ti
7 Bolts	1.4301/A2	A 194 B8
8 Bellow	1.4571	A 276 Grade 316Ti
9 Elongation tube	1.4541	A 213 TP 321
10 Upper part	1.4301	A 276 Grade 304
11 Bush	CW452K	B 159 UNS C51900
12 Stem	1.4301	A 276 Grade 304
13 Gland packing	Graphite / PTFE	
14 Gland nut	1.4305	A 276 Grade 303
15 Handwheel	Aluminium alloy	

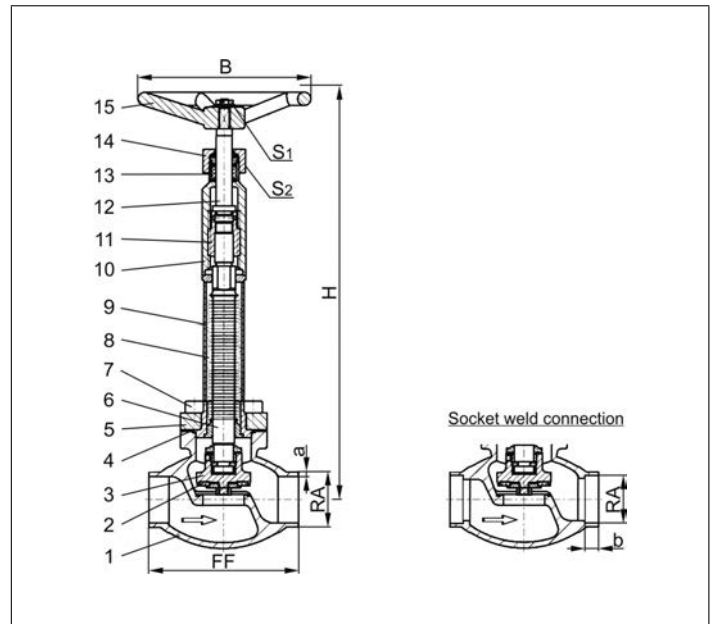

Standard marking acc. to Pressure Equipment Directive 97/23/EC (PED).



Type 01252 - Standard design	Technical data									
Nominal size	DN	10	15	15	20	25	32	40	40	50
Dimension code	.X.	1012	1517	1521	2026	2533	3238	4042	4048	5060
Face-to-face dimension	FF	70	85	85	100	115	115	130	130	155
Height	H	380	380	380	380	380	380	380	380	380
Outside pipe-Ø ISO 1127	RA	12.0	17.2	21.3	26.9	33.7	38.0	42.4	48.3	60.3
Wall thickness pipe ISO 1127	a	1.0	1.6	2.0	2.0	2.0	2.0	2.0	2.0	2.0
Outside pipe-Ø ASTM A312	RA	13.72	17.15	21.34	26.67	33.40	-	42.16	48.26	60.33
Wall thickness pipe ASTM A312	a	dimensions acc. to S10 or S40								
Socket depth	b	6	10	10	13	13	-	13	13	16
Handwheel-Ø	B	150	150	150	150	150	150	150	150	150
Wrench size across flats	S <sub>1</sub>	10	10	10	10	10	13	13	13	13
Wrench size across flats	S <sub>2</sub>	30	30	30	30	30	36	36	36	36
Weight	ca. kg	1.6	1.85	1.9	2.3	2.7	3.6	5.1	5.1	7.7
Kvs-Value	m <sup>3</sup> /h	1.6	2.8	4.3	6.7	11.5	14.0	20.6	22.6	37.1
Cv-Value	gal/min	1.9	3.3	5.0	7.8	13.4	16.2	26.3	26.3	43.2

Dimensions in mm.