

Globe Valves

Type 02401 - Globe Valve



Cryogenic-Globe and Globe/Check Valves, PN50

Bronze body and topwork,
 "live loaded" gland packing
 "cleaned and degreased for oxygen service"

Part No. 02401.X.0008

Part No. 02401.X.5008 Globe/Check Valve

Completed with union type braze fittings for copper pipes acc. to DIN EN 12449 or ASTM B88

Available options - on request only:

- Valve with control disc (tapered design)



Applications:

Approved for air gases, vapours and cryogenic liquefied gases incl. LNG.

Working temperature: -196°C / -321°F (77K) up to +120°C / +248°F (393K)

Recommended working temperature: -60°C / -76°F (213K) up to +120°C / +248°F (393K)

Materials	DIN EN	ASTM
1 Body	CC491K	B 62 UNS C83600
2 Valve seal	PTFE / Carbon filled (25%)	
3 Disc	CW614N	B 283 UNS C38500
4 Bonnet gasket	PTFE	
5 Headpiece	CC493K	B 505 UNS C93200
6 Bolts	1.4301/A2 A 194 B8	
8 Stem	1.4301	A 276 Grade 304
9 Gland packing	Graphite / PTFE	
10 Gland nut	CW614N	B 283 UNS C38500
11 Handwheel	Aluminium alloy	
12 Spring	CW452K	B 159 UNS C51900
13 Braze fitting	CC493K	B 505 UNS C93200
14 Union nut	CC493K	B 505 UNS C93200

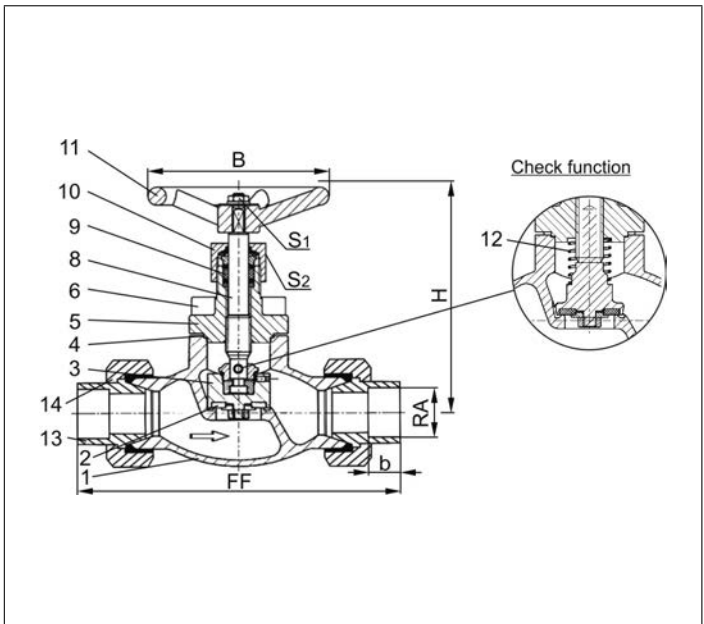

Standard marking acc. to Pressure Equipment Directive 97/23/EC (PED).



Type 02401 - Standard design	Technical data								
Nominal size	DN	10	10	20	20	32	32	40	50
Dimension code	.X.	1012	1015	1518	2022	2528	3235	4042	5054
Face-to-face dimension	FF	98	98	132	132	171	171	230	230
Height	H	140	140	140	140	170	170	175	200
Outside pipe-Ø	RA	12.0	15.0	18.0	22.0	28.0	35.0	42.0	54.0
Socket depth	b	11	11	14	14	17	17	17	17
Handwheel-Ø	B	100	100	100	100	125	125	125	125
Wrench size across flats	S ₁	10	10	10	10	13	13	13	13
Wrench size across flats	S ₂	30	30	30	30	36	36	36	36
Weight	ca. kg	1.2	1.2	2.4	2.4	4.0	4.0	6.3	9.5
Kvs-Value	m ³ /h	1.6	2.2	6.0	6.7	11.5	12.1	22.6	37.1
Cv-Value	gal/min	1.9	2.6	7.1	7.8	13.4	14.1	26.3	43.2

Dimensions in mm.

