

Globe Valves

Type 01341 - Globe Valve



Cryogenic Globe Valves, DN200, PN25

Stainless steel body and topwork
"live loaded" gland packing

Part No. 01341.0219.001* (H=560)

Part No. 01341.0219.006* (H=1000)

*Butt weld connection for stainless steel pipes acc. to ISO 1127 or ASTM A312

Artikel-Nr. 01341.0219.00*4

Socket weld connection for stainless steel pipes acc. to ISO 1127 or ASTM A312

In flow direction, the valve with the nominal size DN200 is conform to tightness class L1 up to 12 bar acc. to DIN 12567 for LNG use. This standard can also be used for the tightness class of other cryogenic gases.

Available options - on request only

Applications:

Approved for air gases, vapours and cryogenic liquefied gases incl. LNG.

Working temperature: -196°C / -321°F (77K) up to +120°C / +248°F (393K)



Materials	DIN EN	ASTM
1 Body	1.4308	A 351 CF8
2 Valve seal	PTFE	
3 Disc	1.4301	A 276 Grade 304
4 Bonnet gasket	PTFE	
5 Headpiece	1.4301	A 276 Grade 304
6 Bolts	1.4301/A2	A 194 B8
7 Elongation tube	1.4541	A 213 TP 321
8 Stem	1.4301	A 276 Grade 304
9 Gland packing	Graphite / PTFE	
10 Gland nut	1.4305	A 276 Grade 303
11 Handwheel	Aluminium alloy	
13 Bush	CW452K	B 159 UNS C51900

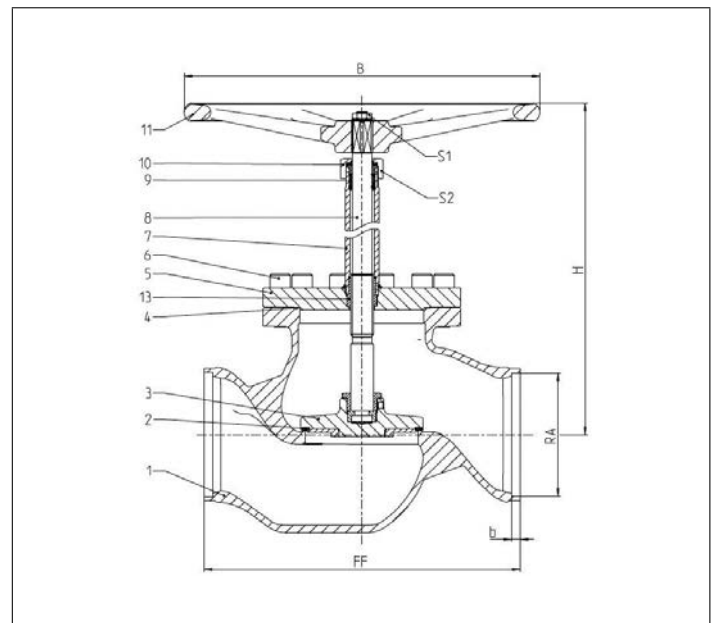

Standard marking acc. to Pressure Equipment Directive 97/23/EC (PED).



Type 01341 - Standard	Technical data	
Nominal size	DN	200
Dimension code	.X.	0219
Face-to-face dimension	FF	560
Height	H	1000
Outside pipe-Ø ISO 1127	RA	219.1
Wall thickness pipe ISO 1127	a	6.3
Outside pipe-Ø ASTM A312	RA	219.1
Wall thickness pipe ASTM A312	a	dimensions acc. to S10 or S40
Socket depth	b	15
Handwheel-Ø	B	630
Wrench size across flats	S ₁	30
Wrench size across flats	S ₂	65
Weight	ca. kg	135
Kvs-Value	m ³ /h	680
Cv-Value	gal/min	786

Dimensions in mm.