

Gate Valves

Type 09061



Gate Valves, PN16, DIN EN 12288

Bronze body, screwed topwork in brass with gland packing and non rising stem

Part No. 09061.X.0160

Flanged connection acc. to DIN EN 1092-1 PN16

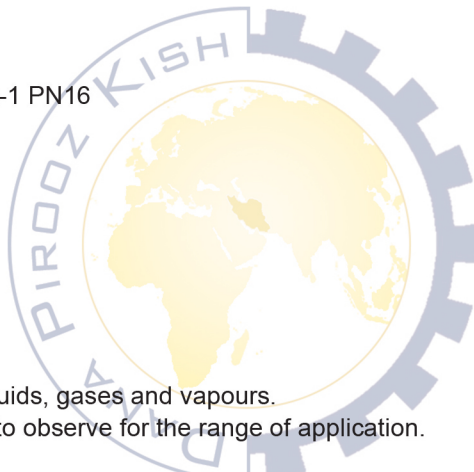

Applications:

Suitable for non-toxic, non-inflammable fluids, gases and vapours.

The laws, regulations and standards are to observe for the range of application.

Working temperatures and pressures:

up to max. 16.0 bar: -10°C / +14°F (263K) up to +120°C / +248°F (393K)

up to max. 10.0 bar: -10°C / +14°F (263K) up to +150°C / +302°F (423K)

up to max. 6.0 bar: -10°C / +14°F (263K) up to +200°C / +392°F (473K)

Materials	DIN EN	ASTM
1 Body	CC491K	B 62 UNS C83600
2 Wedge	CC491K	B 62 UNS C83600
3 Stem	CW614N	B 283 UNS C38500
4 Headpiece	CW614N	B 283 UNS C38500
5 Handwheel	Aluminium - diecasting	

Essential: When ordering or requesting an offer please indicate flow medium, working pressure and working temperature.

Standard marking acc. to Pressure Equipment Directive 97/23/EC (PED).

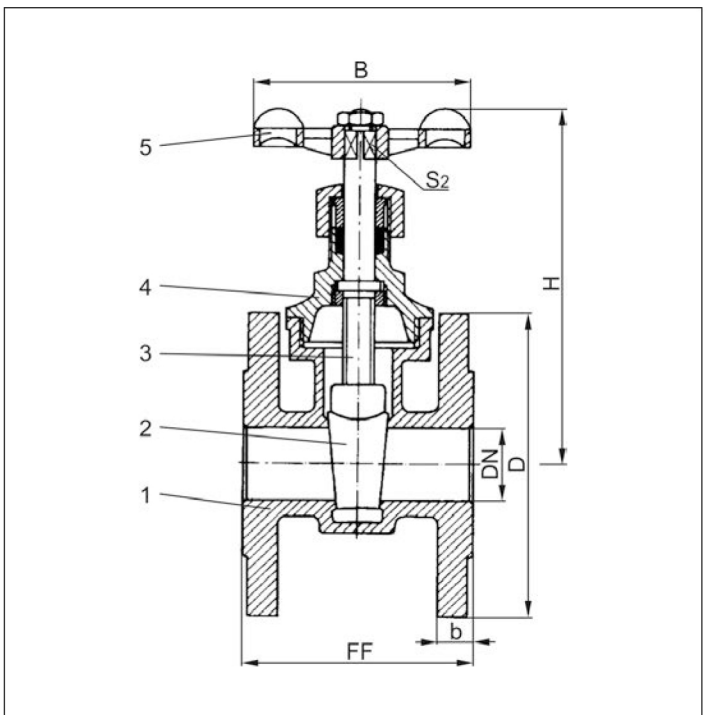

Type 09061	Technical data							
Nominal size	DN	20	25	32	40	50	65	80
Dimension code	.X.	0200	0250	0320	0400	0500	0650	0800
Face-to-face dimension	FF	75	80	90	100	110	130	150
Height	H	105	115	130	150	180	220	250
Flange diameter	D	105	115	140	150	165	185	200
Width of flange	b	12	12	14	14	16	16	18
Handwheel-Ø	B	70	70	80	80	110	150	160
Wrench size across flats	S ₂	7	8	9	9	11	12	13
Weight	ca. kg	1.8	2.3	3.6	4.6	6.4	9.4	12.1

Dimensions in mm.