

Gate Valves

Type 09420



Flanged Gate Valves, PN16, DIN EN 12288

Bronze body, screwed topwork in brass
with maintenance-free gland packing (O-Ring)
and non rising stem
flanged connection acc. to DIN EN 1092-3 PN16

Part No. 09420.X.000000

· Standard valve

Part No. 09420.X.010000

· Valve with locking device without lock

Part No. 09420.X.020000

· Valve with locking device with lock

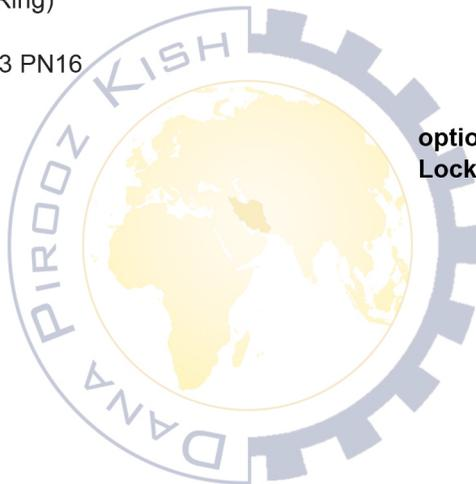

option:
Locking device →



Applications:

Suitable for transformer oil.

Working temperatures: -25°C / -13°F (248K) up to +120°C / +248°F (393K) and maximal 6.0 bar

Materials	DIN EN	ASTM
1 Body	CC491K	B 62 UNS C83600
2 Wedge	CC491K	B 62 UNS C83600
3 Stem	CW614N	B 283 UNS C38500
4 Bonnet gasket	Klingersiel C-4400	
5 Headpiece	CW614N	B 283 UNS C38500
6 O-Rings	FPM (Viton)	
7 Handwheel	Aluminium - diecasting	

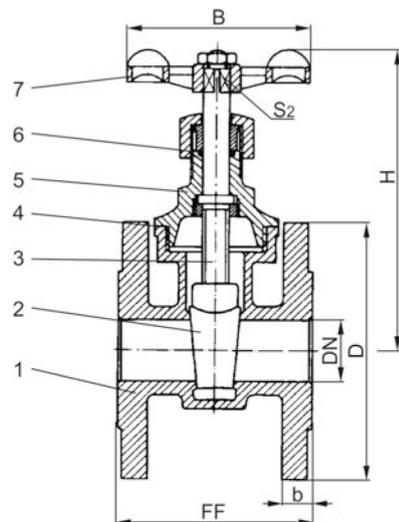

Essential: When ordering or requesting an offer please indicate flow medium, working pressure and working temperature.

Standard marking acc. to Pressure Equipment Directive 97/23/EC (PED).



Type 09420	Technical data							
Nominal size	DN	25	32	40	50	65	80	100
Dimension code	.X.	0250	0320	0400	0500	0650	0800	1000
Face-to-face dimension	FF	80	90	100	110	130	150	165
Height	H	120	130	150	180	225	250	300
Flange diameter	D	115	140	150	165	185	200	220
Width of flange	b	12	14	14	16	16	18	20
Handwheel-Ø	B	70	80	80	110	150	150	150
Wrench size across flats	S ₂	8	9	9	11	12	14	14
Weight	ca. kg	2.6	3.6	4.4	6.5	9.2	12.1	15.8

Dimensions in mm.