

Gate Valves

Type 09320



Flanged Gate Valves, PN10 - 16, DIN EN 12288

Bronze body and topwork
with maintenance-free gland packing (O-Ring) and non rising stem
flanged connection acc. to DIN EN 1092-3 PN10 or PN16

Part No. 09320.X.110000

· Valve with opening indicator and locking device without lock

Part No. 09320.X.120000

· Valve with opening indicator and locking device with lock



Applications:

Suitable for transformer oil.

Working temperatures: -25°C / -13°F (248K) up to +120°C / +248°F (393K) and maximal 6.0 bar

Materials	DIN EN	ASTM
1 Body	CC491K	B 62 UNS C83600
2 Wedge	CC491K	B 62 UNS C83600
3 Stem	CW614N	B 283 UNS C38500
4 Bonnet gasket	Klingsil C-4400	
5 Headpiece	CC491K	B 62 UNS C38600
6 Bolts	1.471/A4	similar A 194 B8T
7 O-Rings	FPM (Viton)	
8 Handwheel	Aluminium - diecasting	

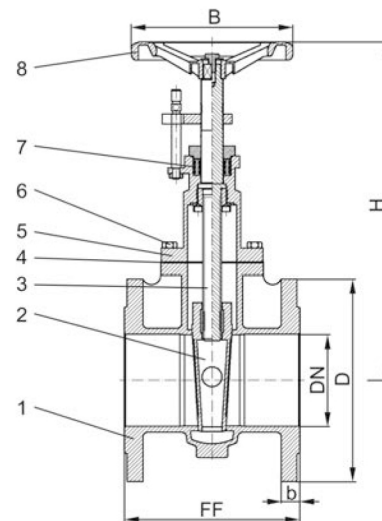

Essential: When ordering or requesting an offer please indicate flow medium, working pressure and working temperature.

Standard marking acc. to Pressure Equipment Directive 97/23/EC (PED).



Type 09320	Technical data					
Nominal size	DN	100	125	150	200	250
Dimension code	X	1000	1250	1500	2000	2500
Max. working pressure	PN	16	16	10	10	10
Face-to-face dimension	FF	190	208	210	230	250
Height	H	372	410	467	597	940
Flange diameter	D	220	250	285	340	395
Flange connect DIN EN 1092-3	PN	16	16	16	10	10
Width of flange	b	20	25	22	24	24
Handwheel-Ø	B	175	200	225	250	300
Weight	ca. kg	28.0	31.0	39.0	66.0	106.0

Dimensions in mm.