

Cryogenic-Check Valves, PN40

Stainless steel body and cap
with spring, opening pressure ca. 0.1 bar
"cleaned and degreased for oxygen service"

Part No. 05419.X.0002

Flanged connection acc. to DIN EN 1092-1 PN40

Available options - on request only:

- Nominal sizes DN15, DN20 and DN150 with welding-neck flange

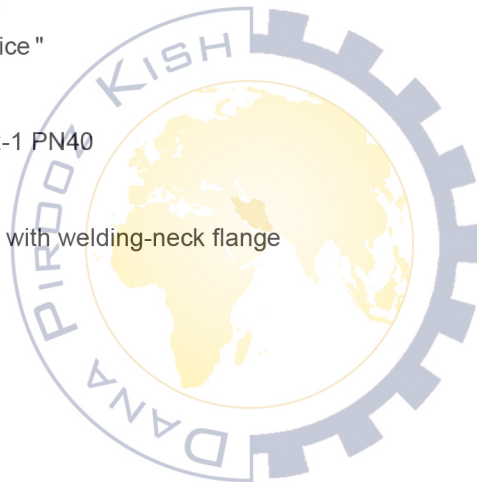

Applications:

Approved for air gases, vapours and cryogenic liquefied gases incl. LNG.

Working temperature: -196°C / -321°F (77K) up to +120°C / +248°F (393K)

Materials	DIN EN	ASTM
1 Body	1.4308	A 351 CF8
2 Valve seal up to DN50	PTFE / Carbon filled (25%)	
2a Valve seal from DN65	PTFE	
3 Disc	1.4301	A 276 Grade 304
4 Spring	1.4571	A 313 Grade 316Ti
5 Bonnet gasket	PTFE	
6 Bolts	1.4301/A2	A 194 B8
7 Cap	1.4301	A 276 Grade 304

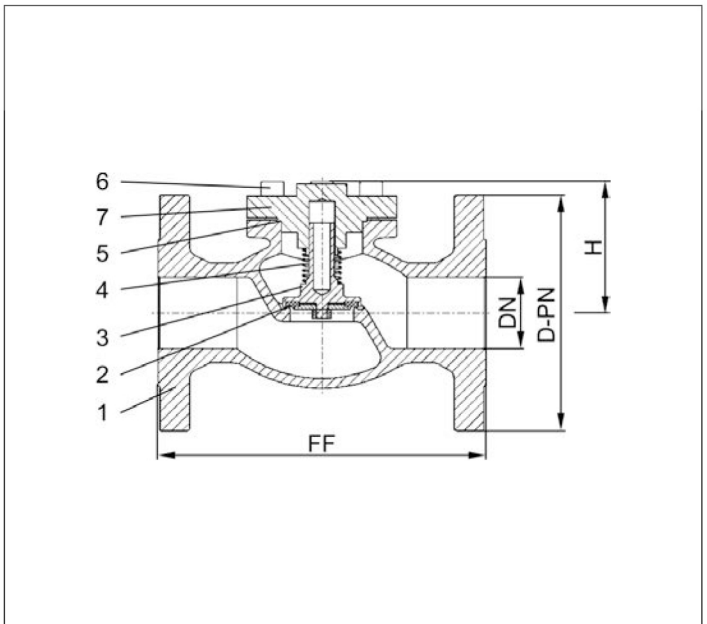

Standard marking acc. to Pressure Equipment Directive 97/23/EC (PED).



Type 05419 - Standard design	Technical data						
Nominal size	DN	25	40	50	65	80	100
Dimension code - Flange EN 1092-1 PN40	.X.	0250	0400	0500	0650	0800	1000
Flange-Ø	D-PN	115	150	165	185	200	235
Face-to-face dimension	FF	160	200	230	290	310	350
Height	H	75	95	90	125	150	165
Weight	ca. kg	4.4	6.4	11.6	19.2	25.2	39.8
Kvs-Value	m ³ /h	11.5	22.6	37.1	71.1	104.0	170.0
Cv-Value	gal/min	13.4	26.3	43.2	82.7	120.9	195.2

Dimensions in mm.