

Cryogenic-Check Valves, class 300

Stainless steel body and bronze cap
with spring, opening pressure ca. 0.1 bar
"cleaned and degreased for oxygen service"

Part No. 05418.X.0003

Flanged connection acc. to ANSI B16.5 class 300

Available options - on request only:

- Nominal sizes DN15, DN20 and DN150 with welding-neck flange

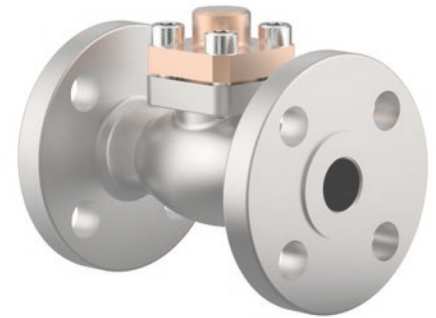

Applications:

Approved for air gases, vapours and cryogenic liquefied gases incl. LNG.

Working temperature: -196°C / -321°F (77K) up to +120°C / +248°F (393K)

Materials	DIN EN	ASTM
1 Body	1.4308	A 351 CF8
2 Valve seal up to DN50	PTFE / Carbon filled (25%)	
2a Valve seal from DN65	PTFE	
3 Disc	CW614N	B 283 UNS C38500
4 Spring	CW452K	B 159 UNS C51900
5 Bonnet gasket	PTFE	
6 Bolts	1.4301/A2	A 194 B8
7 Cap	CC493K	B 505 UNS C93200

Standard marking acc. to Pressure Equipment Directive 97/23/EC (PED).

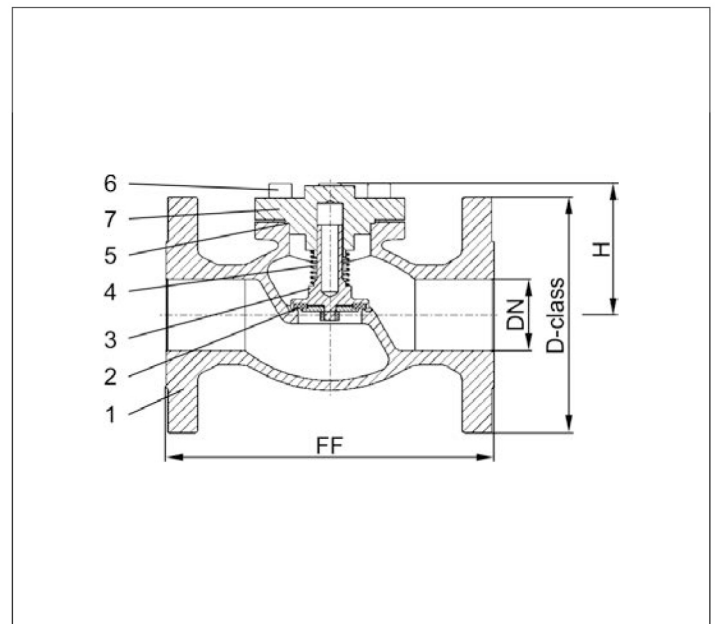

Type 05418 - Standard design	Technical data						
Nominal size	DN	25	40	50	65	80	100
Dimension code - Flange ANSI B16.5 class 300	.X.	1000	1400	2000	2400	3000	4000
Flange-Ø	D-class	123.9	155.4	165	190.5	209.5	254
Face-to-face dimension	FF	160	200	230	290	310	350
Height	H	75	95	90	125	150	165
Weight	ca. kg	4.4	6.4	11.6	19.2	25.2	39.8
Kvs-Value	m ³ /h	11.5	22.6	37.1	71.1	104.0	170.0
Cv-Value	gal/min	13.4	26.3	43.2	82.7	120.9	195.2

Dimensions in mm.