

Safety Valves

Type 06345, Type 06346



Safety Valves, angle type, cast steel, type tested, TÜV-SV.576. D/G/F

Full lift safety valve

Standard safety valve for fluids
metal to metal seated, with lifting device,
with enlarged outlet

Inlet: Flanged connection acc. to DIN EN 1092-1 PN40

Outlet: Flanged connection acc. to DIN EN 1092-1 PN16

Part No. 06345.X.0000

open bonnet

Part No. 06346.X.0000

closed bonnet

Available options - on request only:

· Disc with soft sealing · Extended pressure and temperature ranges

Applications:

Provided as safety device for protection against excessive pressure in pressure vessels.

Approved for gases, vapours and fluids.

Working temperatures: -85°C / -121°F (188K) up to +450°C / +842°F (723K)



Materials	DIN EN	ASTM
1 Body	1.0619	A 216 Grade WCB
2 Seat	1.4404	A 276 Grade 316L
3 Disc	1.4122	no reference
4 Stem	1.4021	A 276 Grade 420
5 Spring	1.1200	A 227
6 Bonnet	1.0619	A 216 Grade WCB
7 Lifting device	0.7040	A 536-87 Gr. 60-40-18

Essential: Valves are delivered at a set pressure, therefore when ordering please confirm set pressure, medium and temperature.

Standard marking acc. to Pressure Equipment Directive 97/23/EC (PED).



Marking acc. to ASME Code Section VIII.

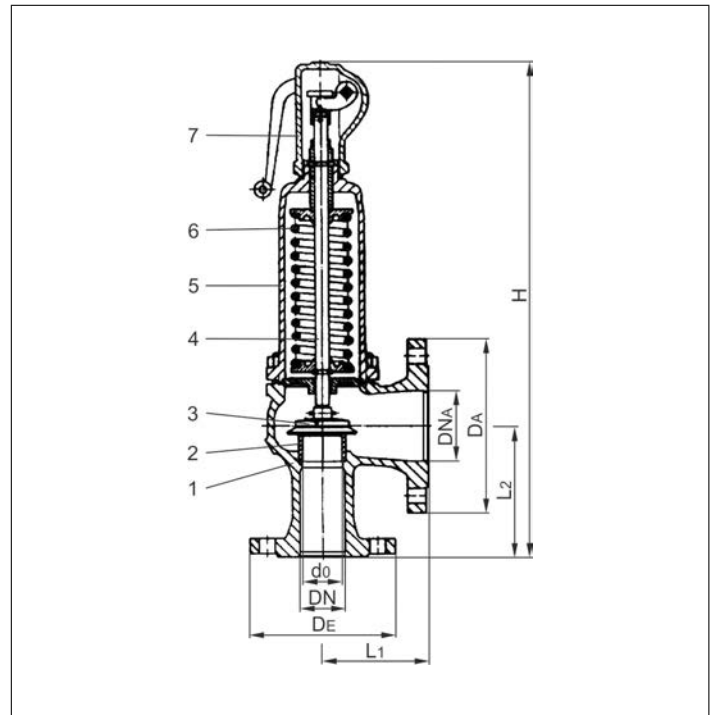

Type 06345. 06346	Technical data									
Nominal size	DN	25	32	40	50	65	80	100	125	150
Outlet	DN	40	50	65	80	100	125	150	200	250
Orifice	d ₀	23	29	37	46	60	74	92	98	125
Dimension code	.X.	0250	0320	0400	0500	0650	0800	1000	1250	1500
Set pressure saturated steam	bar	0.2-32	0.2-32	0.2-32	0.2-32	0.2-32	0.2-32	0.2-32	0.2-24	0.2-16
Set pressure air and fluids	bar	0.2-40	0.2-40	0.2-40	0.2-40	0.2-34	0.2-34	0.2-32	0.2-24	0.2-16
Flange diameter	D _E	115	140	150	165	185	200	220	250	285
Flange diameter	D _A	150	165	185	200	220	250	285	340	405
Height Type 06345	H	338	440	506	563	696	798	880	910	1020
Height Type 06346	H	339	446	512	569	702	801	883	913	1020
Length	L ₁	100	110	115	120	140	160	180	200	225
Length	L ₂	105	115	140	150	170	195	220	250	285
Weight	ca. kg	9.0	12.0	16.0	22.0	32.0	56.0	75.0	85.0	131.0
Coeff. of discharge gases, vapours	α _w	0.70	0.70	0.70	0.70	0.70	0.70	0.70	0.70	0.70
Coeff. of discharge fluids	α _w	0.45	0.45	0.45	0.45	0.45	0.45	0.45	0.45	0.45

Dimensions in mm.

Safety Valves

Type 06345, Type 06346



Discharge capacities

Calculation of mass flow acc. to AD2000-Merkblatt A2

Medium:

A = Saturated steam in kg/h

B = Air in m³/h at 0°C and 1013.25 mbar

C = Water in kg/h at 20°C

The capacity indicated below is for a fully opened valve.

d₀ - orifice

A₀ - flow area

Set pressure in bar (g)	DN	25			32			40			50			65		
	d ₀ (mm)	23			29			37			46			60		
	A ₀ (mm ²)	415.5			660.6			1075.3			1662.1			2827.8		
	Medium	A	B	C	A	B	C	A	B	C	A	B	C	A	B	C
0.2	140	162	5210	223	258	8280	363	420	13500	561	649	20800	954	1105	35500	
0.5	224	263	7370	356	418	11700	579	680	19100	895	1051	29500	1523	1789	50100	
1.0	326	388	9970	518	617	15900	843	1004	25800	1302	1552	39900	2215	2641	67900	
2.0	519	627	14100	825	996	22400	1343	1622	36500	2075	2507	56400	3531	4265	96000	
3.0	699	854	17300	1111	1357	27500	1808	2209	44700	2794	3414	69100	4754	5809	118000	
4.0	871	1071	19900	1385	1703	31700	2254	2773	51600	3485	4286	79800	5928	7291	136000	
5.0	1043	1289	22300	1658	2050	35500	2699	3337	57700	4172	5157	89200	7097	8774	152000	
6.0	1214	1507	24400	1930	2396	38800	3142	3900	63200	4856	6029	97700	8262	10257	166000	
7.0	1381	1725	26400	2196	2742	42000	3574	4464	68300	5525	6900	106000	9399	11739	180000	
8.0	1551	1943	28200	2466	3089	44800	4014	5028	73000	6205	7771	113000	10556	13222	192000	
9.0	1721	2161	29900	2736	3435	47600	4454	5592	77400	6884	8643	120000	11712	14704	204000	
10.0	1891	2379	31500	3006	3781	50100	4893	6155	81600	7562	9514	126000	12866	16187	215000	
12.0	2230	2814	34600	3545	4474	54900	5770	7283	89400	8919	11257	138000	15174	19152	235000	
16.0	2900	3686	39900	4610	5859	63400	7505	9538	103000	11600	14743	160000	19735	25082	272000	
20.0	3578	4557	44600	5688	7245	70900	9260	11793	115000	14312	18228	178000	24350	31012	304000	
24.0	4247	5429	48900	6752	8630	77700	10991	14048	126000	16988	21714	195000	28903	36943	333000	
28.0	4930	6300	52800	7837	10016	83900	12757	16304	137000	19718	25200	211000	33547	42873	359000	
32.0	5616	7171	56400	8929	11401	89700	14534	18559	146000	22465	28685	226000	38220	48803	384000	
34.0	5945	7607	58200	9451	12094	92500	15384	19686	151000	23779	30428	233000	40455	51768	396000	
36.0	6290	8043	59800	10000	12786	95100	16278	20814	155000	25160	32171	239000	42806	54733	407000	
40.0	6985	8914	63100	11104	14172	100000	18076	23059	163000	27939	35657	252000	47533	60663	429000	

Set pressure in bar (g)	DN	80			100			125			150		
	d ₀ (mm)	74			92			98			125		
	A ₀ (mm ²)	4301.4			6648.5			7543.9			12273.4		
	Medium	A	B	C	A	B	C	A	B	C	A	B	C
0.2	1451	1680	53900	2243	2597	83300	2545	2947	94600	4140	4794	154000	
0.5	2316	2721	76300	3580	4206	118000	4062	4772	134000	6609	7764	218000	
1.0	3370	4017	103000	5209	6209	160000	5910	7045	181000	9616	11461	295000	
2.0	5371	6487	146000	8302	10026	226000	9420	11377	256000	15326	18509	417000	
3.0	7232	8836	179000	11178	13657	276000	12683	15497	314000	20635	25212	510000	
4.0	9018	11091	206000	13938	17143	319000	15816	19462	362000	25731	31647	589000	
5.0	10796	13346	231000	16687	20629	357000	18934	23407	405000	30804	38082	659000	
6.0	12568	15601	253000	19426	24114	391000	22042	27362	444000	35861	44516	722000	
7.0	14297	17857	273000	22098	27600	422000	25074	31317	479000	40794	50951	779000	
8.0	16057	20112	292000	24818	31086	451000	28161	35273	512000	45816	57386	833000	
9.0	17815	22367	310000	27535	34571	479000	31244	39228	543000	50831	63821	884000	
10.0	19571	24622	326000	30250	38057	505000	34324	43183	573000	55842	70255	932000	
12.0	23081	29132	358000	35675	45028	553000	40480	51093	627000	65858	83125	1021000	
16.0	30020	38153	413000	46400	58971	638000	52650	66914	724000	85657	108863	1178000	
20.0	37039	47173	462000	57249	72913	714000	64960	82734	810000	105685	134602	1317000	
24.0	43964	56194	506000	67953	86856	782000	77106	98555	887000	125445	160341	1443000	
28.0	51029	65214	546000	78873	100793	844000	89496	114375	958000	-	-	-	
32.0	58137	74235	584000	89860	114741	-	-	-	-	-	-	-	
34.0	61537	78745	602000	95115	121713	-	-	-	-	-	-	-	
36.0	65112	83255	619000	10064	128684	-	-	-	-	-	-	-	
40.0	72303	92276	653000	111756	142626	-	-	-	-	-	-	-	