

Cryogenic-Check Valves, PN50

Bronze body and cap
with spring, opening pressure ca. 0.1 bar
"cleaned and degreased for oxygen service"

Part No. 05411.X.0007

Completed with union type butt weld fittings for stainless steel pipes
acc. to ISO 1127 or ASTM A312

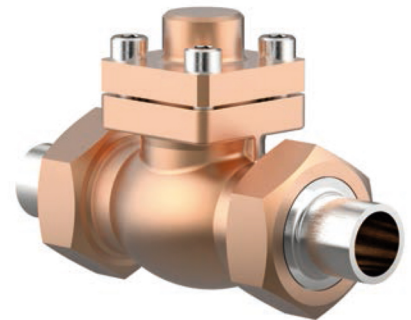
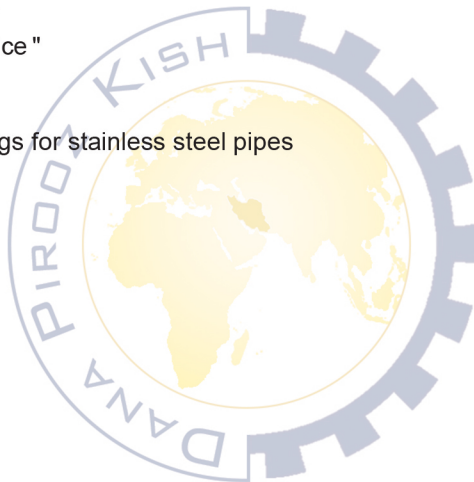

Applications:

Approved for air gases, vapours and cryogenic liquefied gases incl. LNG.
Working temperature: -196°C / -321°F (77K) up to +120°C / +248°F (393K)

Materials	DIN EN	ASTM
1 Body	CC491K	B 62 UNS C83600
2 Valve seal	PTFE / Carbon filled (25%)	
3 Disc	CW614N	B 283 UNS C38500
4 Spring	CW452K	B 159 UNS C51900
5 Bonnet gasket	PTFE	
6 Bolts	1.4301/A2	A 194 B8
7 Cap	CC493K	B 505 UNS C93200
8 Weld fitting	1.4301	A 276 Grade 304
9 Union nut	CC493K	B 505 UNS C93200

Standard marking acc. to Pressure Equipment Directive 97/23/EC (PED).

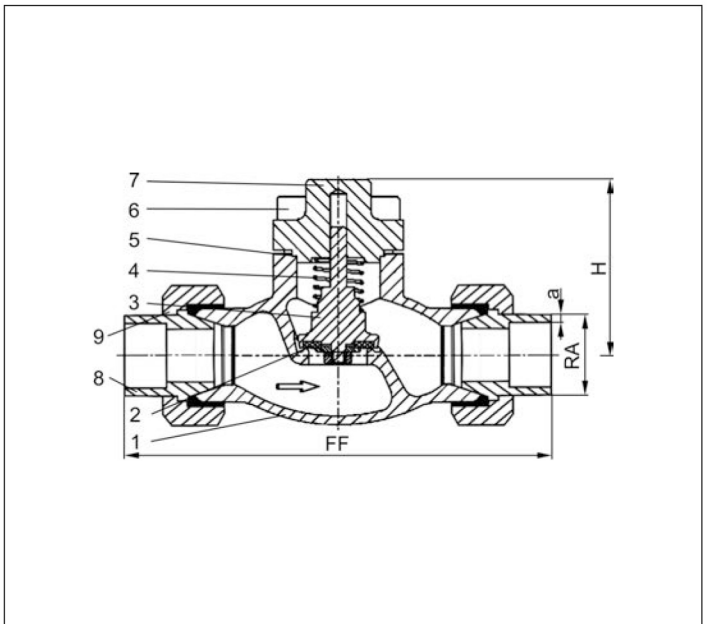

Type 05411 - Standard design	Technical data								
Nominal size	DN	10	10	20	20	32	32	40	50
Dimension code	X.	1012	1017	1521	2027	2533	3242	4048	5060
Face-to-face dimension	FF	137	141	168	168	203	203	230	263
Height	H	71	71	72	72	87	87	95	95
Outside pipe-Ø ISO 1127	RA	12.0	17.2	21.3	26.9	33.7	42.4	48.3	60.3
Wall thickness pipe ISO 1127	a	1.0	2.3	2.6	2.0	3.2	2.0	3.6	3.6
Outside pipe-Ø ASTM A312	RA	-	17.15	21.34	26.67	33.40	42.16	48.26	60.33
Wall thickness pipe ASTM A312	a	dimensions acc. to S10 or S40							
Weight	ca. kg	0.9	0.9	2.0	2.0	3.6	3.6	6.0	8.5
Kvs-Value	m ³ /h	1.6	2.2	6.7	6.7	12.1	12.1	22.6	37.1
Cv-Value	gal/min	1.9	2.6	7.8	7.8	14.1	14.1	26.3	43.2

Dimensions in mm.